

附錄4. 牙制資料

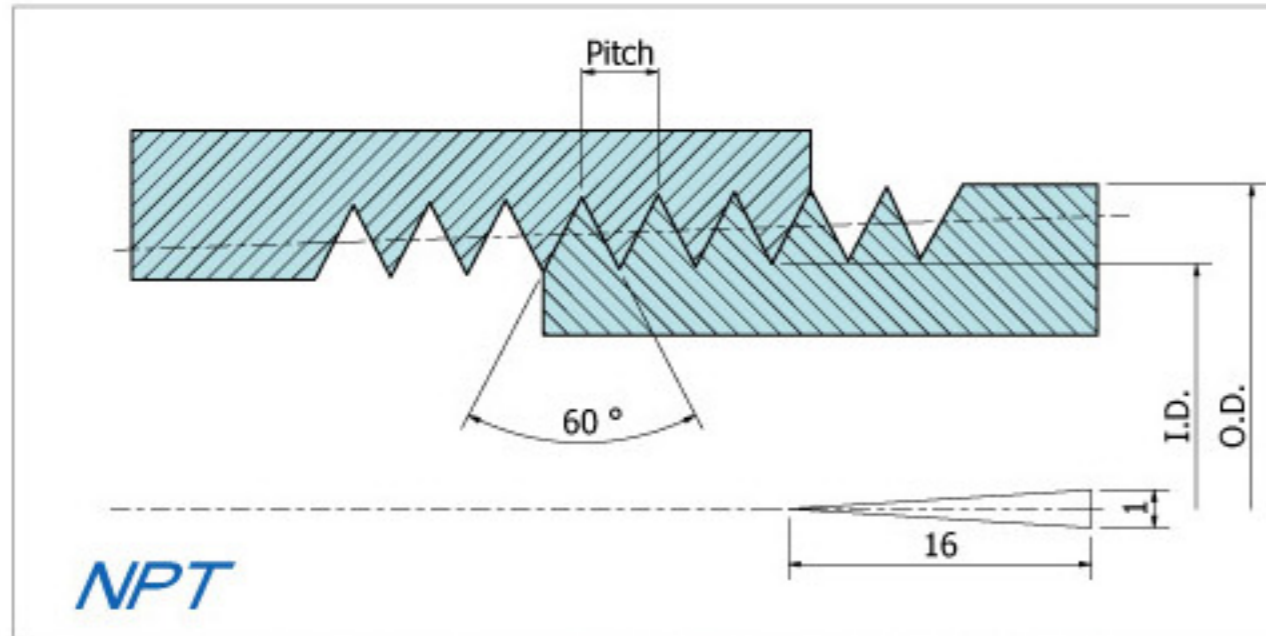

US taper seal pipe thread ANSI/ASME B1.20.1-1983

Thread size (inch)	Thread		Pitch	Threads inch
	O.D.	I.D.		
3/8"	16.7	15.0	1.41	18
1/2"	21.0	18.0	1.81	14
3/4"	26.4	23.7	1.81	14
1"	33.3	29.7	2.21	11.5
1-1/4"	41.9	38.5	2.21	11.5
1-1/2"	47.8	44.5	2.21	11.5
2"	59.6	56.6	2.21	11.5
2-1/2"	72.7	67.6	3.18	8
3"	88.6	83.5	3.18	8
4"	114.0	108.9	3.18	8

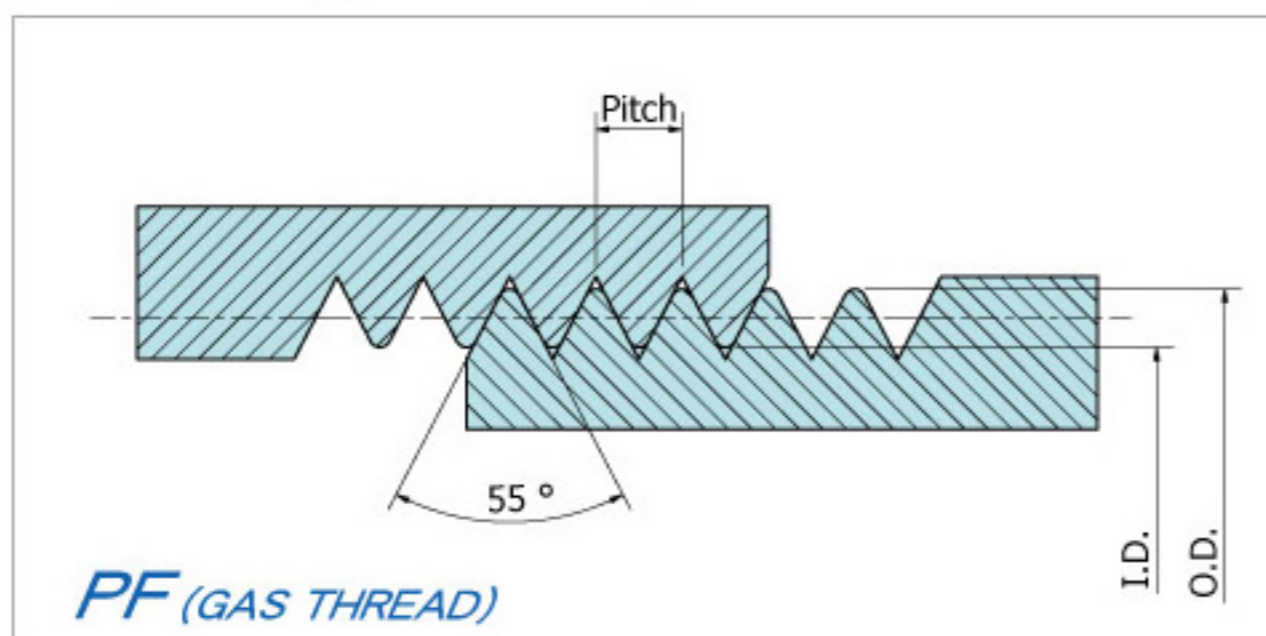

Japanese JIS B0202

Thread size (inch)	Thread		Pitch	Threads inch
	O.D.	I.D.		
G 3/8"	16.7	15.0	1.34	19
G 1/2"	21.0	18.6	1.81	14
G 3/4"	26.4	24.1	1.81	14
G 1"	33.3	30.3	2.31	11
G 1-1/4"	41.9	39.0	2.31	11
G 1-1/2"	47.8	44.8	2.31	11
G 2"	59.6	56.7	2.31	11
G 2-1/2"	75.2	72.2	2.31	11
G 3"	87.9	84.9	2.31	11
G 4"	113.0	110.1	2.31	11

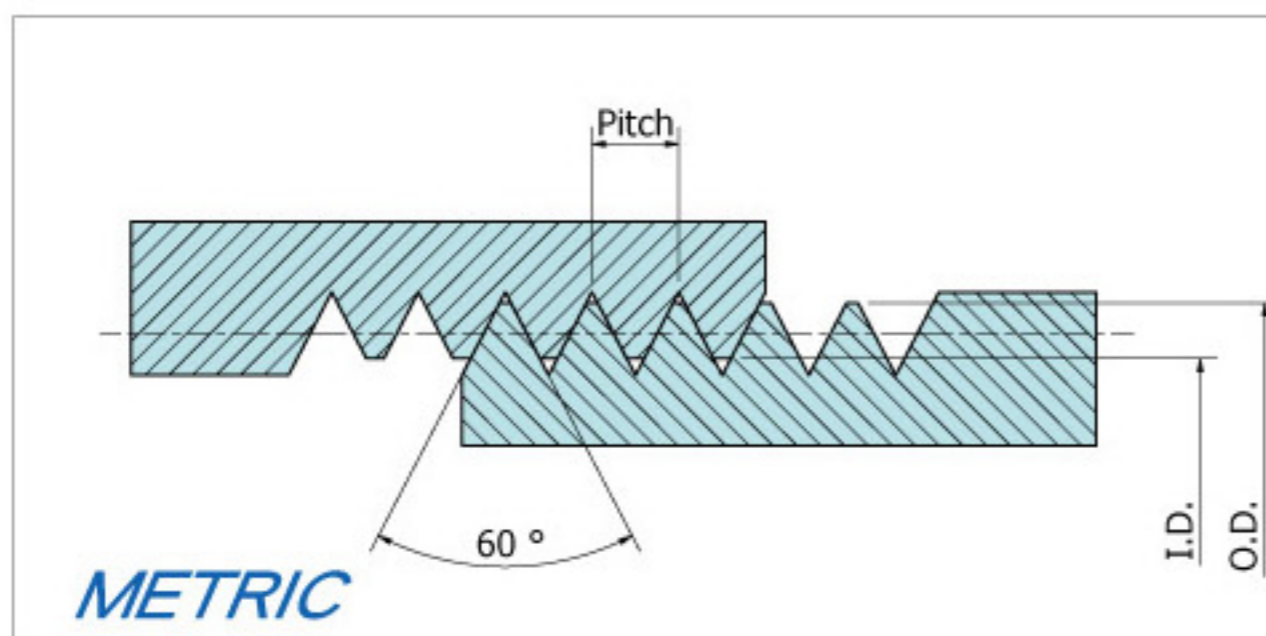

EN60423 & BS3643

Thread size (inch)	Thread		Pitch	Threads inch
	O.D.	I.D.		
M10	10.0	8.9	1.0	25.4
M12	12.0	10.9	1.0	25.4
M16	16.0	14.4	1.5	17
M20	20.0	18.4	1.5	17
M25	25.0	23.4	1.5	17
M32	32.0	30.4	1.5	17
M40	40.0	38.4	1.5	17
M50	50.0	48.4	1.5	17
M63	63.0	61.4	1.5	17
M75	75.0	73.4	1.5	17

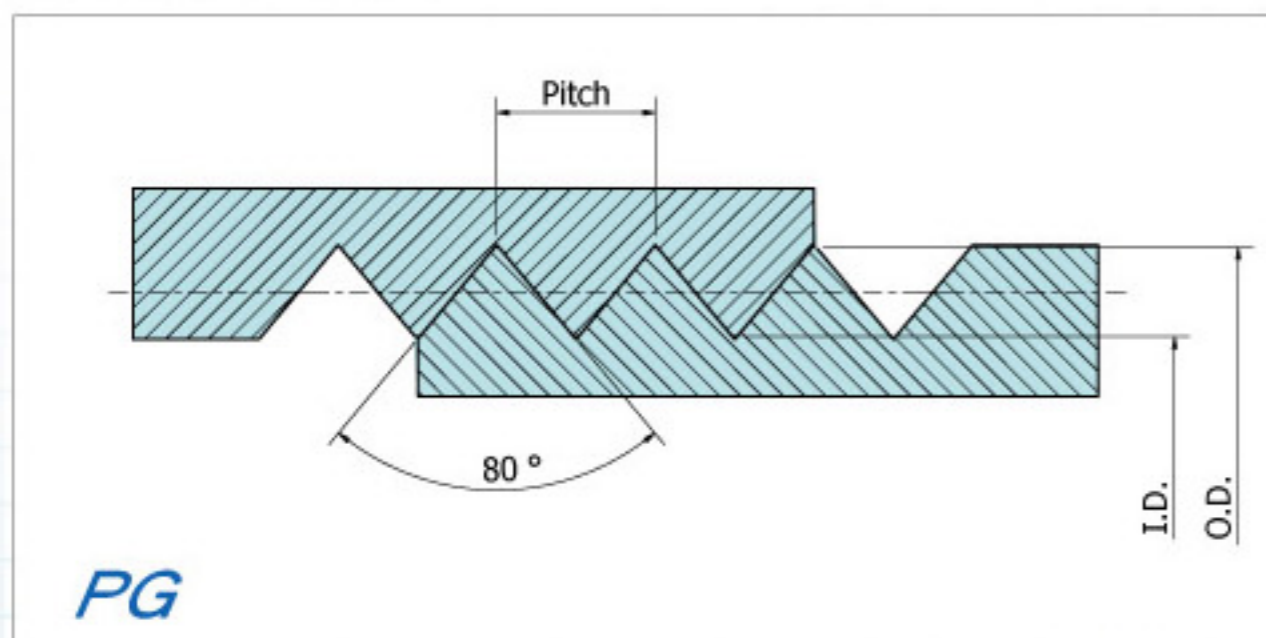

German Standard DIN40430

Thread size (inch)	Thread		Pitch	Threads inch
	O.D.	I.D.		
PG7	12.5	11.3	1.27	20
PG9	15.2	13.9	1.41	18
PG11	18.6	17.3	1.41	18
PG13.5	20.4	19.1	1.41	18
PG16	22.5	21.2	1.41	18
PG21	28.3	26.8	1.59	16
PG29	37.0	35.5	1.59	16
PG36	47.0	45.5	1.59	16
PG42	54.0	52.5	1.59	16
PG48	59.3	57.8	1.59	16

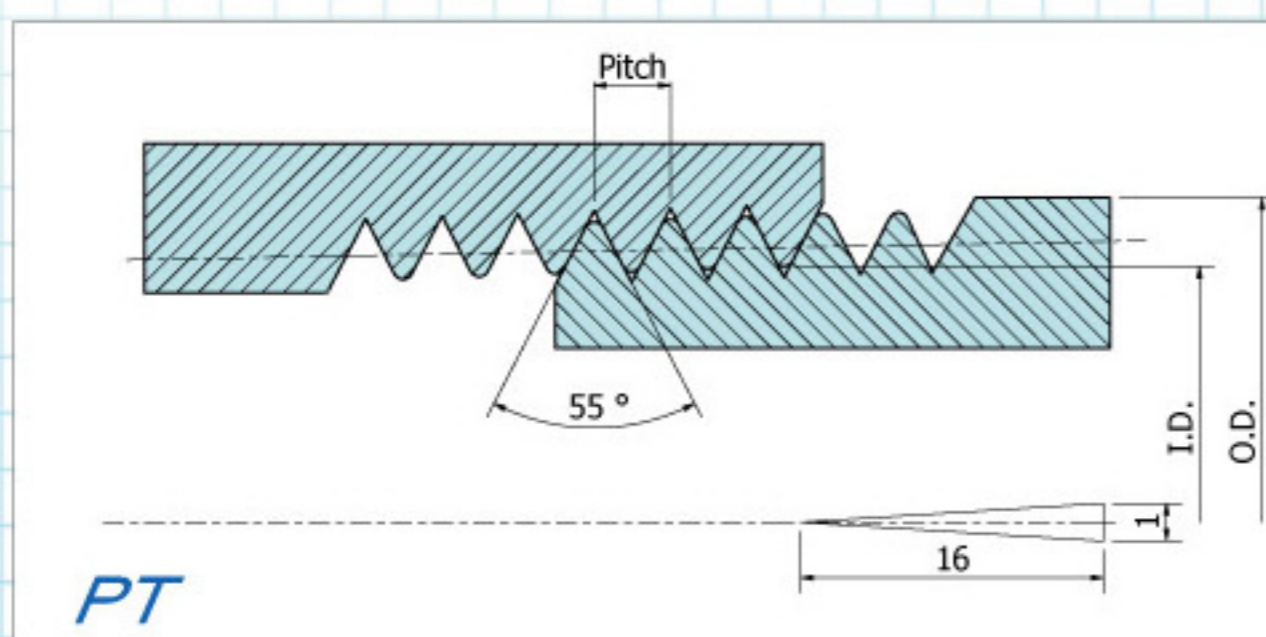

Japanese JIS B0203

Thread size (inch)	Thread		Pitch	Threads inch
	O.D.	I.D.		
R 1/2"	21.0	18.6	1.81	14
R 3/4"	26.4	24.1	1.81	14
R 1"	33.3	30.3	2.31	11
R 1-1/4"	41.9	39.0	2.31	11
R 1-1/2"	47.8	44.8	2.31	11
R 2"	59.6	56.7	2.31	11
R 2-1/2"	75.2	72.2	2.31	11
R 3"	87.9	84.9	2.31	11
R 4"	113.0	110.1	2.31	11